



Customer's Name:

客户名称:

Spec.No. :

Item Coding:

Ver: A1

Date: 2020-12-24

Shenzhen Giant Power Co., Ltd

深圳市巨博能源有限公司

## Specification For Approval

### 客户承认书

Specifications : 24140160-16S4P-51.2V 200Ah (壁挂)

规格: 24140160-16S4P-51.2V 200Ah (壁挂)

Approval	Checked	Draft
Customer Approval		

address: No.2 Factory Building, Baimenqian Industrial Zone, Longgang District, Shenzhen, Guangdong, China

地址: 广东省深圳市龙岗区百门前工业区 2 栋



## Contents 目录

1. Scope 适用范围 .....	4
2. Main specifications 主要技术参数 .....	4
2.1 Cell Battery specifications (电芯技术参数) .....	4
2.2 Battery Pack specifications (电池组技术参数) .....	5
3. Battery Management System Specification 电池管理系统规范 .....	6
3.1 BMS function introduction (BMS 功能介绍) .....	6
3.2 BMS Protect parameter (电池管理系统保护参数) .....	6
4. Appearance and structural dimensions 外观结构尺寸 .....	7
5. Case Structure of Battery Pack 电池组面板结构定义 .....	8
6. Connection mode for parallel communication (并机通讯联接) .....	9
7. Packaging of Battery Pack(电池组包装) .....	9
8. Battery test equipment 电池测试设备 .....	10
8.1 Dimension Measuring Instrument 尺寸测量仪器 .....	10
8.2 Voltmeter 电压表 .....	10
8.3 Ammeter 电流表 .....	10
8.4 Impedance Meter 内阻测试仪 .....	11
9. Standard Test Condition 标准测试条件 .....	11
10. Storage and Others 贮存及其它事项 .....	11
10.1 Long Time Storage 长期贮存 .....	11
10.2 Others 其它事项 .....	11
11. Amendment of this Specification 产品规格书的修订 .....	11
12. Appendix 附录 .....	11

## 1. Scope 适用范围

The specification shall be applied to LiFePO4 rechargeable battery pack Of 24140160-16S4P which is manufactured by Shenzhen Giant Power Co., Ltd.

本规格书适用于深圳市巨博能源有限公司生产的 24140160-16S4P 磷酸铁锂锂离子可充电电池。

## 2. Main specifications 主要技术参数

### 2.1 Cell Battery specifications (电芯技术参数)

No. (序号)	Item (项目)	General Parameter (常规参数)		Remark (备注)
		Typical (标称容量)	50Ah	
1	Rated Capacity (额定容量)	Minimum (最小容量)	50Ah	Standard discharge (0.2C <sub>5</sub> A) after Standard charge (标准充电后 0.2C <sub>5</sub> A 标准放电)
2	Nominal Voltage (正常电压)	3.2V		Mean Operation Voltage (即工作电压)
3	Internal Impedance (内阻)	≤0.65 mΩ		Internal resistance measured at AC 1KHz after 50% charge (半电态下用交流法测量内阻) The measure must uses the new batteries that within one week after shipment and cycles less than 5 times (使用出货后不到一个星期及循环 次数少于 5 次的新电池测量)
4	Dimension (尺寸)	Thickness/厚度: Max 24.5mm		Initial Dimension (初始尺寸)
		Width/宽度: Max 140.5mm		
		Height/高度: Max 160.5mm		
5	Weight (重量)	1.15kg		APPROX
6	Standard charge (标准充电)	Constant Current 0.33C <sub>5</sub> A Constant Voltage 3.65V 0.02C <sub>5</sub> A cut-off (持续电流: 0.33C <sub>5</sub> A 持续电压: 3.65V 截止电流: 0.02C <sub>5</sub> A)		Charge time : Approx 3.5h
7	Rapid Charge 快速充电	Constant Current 1C <sub>5</sub> A Constant Voltage 3.65V 0.01C <sub>5</sub> A cut-off (持续电流: 1C <sub>5</sub> A 持续电压: 3.65V 截止电流: 0.01C <sub>5</sub> A)		Charge time : Approx 1.5h @ ≥ 10°C
8	Standard discharge (标准放电)	Constant current 0.33C <sub>5</sub> A end voltage 2.5 V (持续电流: 0.33C <sub>5</sub> A 截止电压: 2.5V)		16.5A
9	Maximum discharge current 最大放电持续电流	Constant current: 2C <sub>5</sub> A end voltage: 2.5 V (持续电流 2C <sub>5</sub> A 截止电压: 2.5V)		100A @ ≥ 0°C
10	Volumetric specific energy (体积比能量)	295 WH/L		APPROX
11	Gravimetric specific energy (质量比能量)	139WH/KG		APPROX

## 2.2 Battery Pack specifications (电池组技术参数)

No. (序号)	Item (项目)	General Parameter (常规参数)		Remark (备注)
1	Combination method (组合方式)	16S4P		
2	Rated Capacity (额定容量)	Typical (标称容量)	200Ah	Standard discharge after Standard charge (package) (标准充电后标准放电 (针对电池组))
		Minimum (最小容量)	196Ah	
3	Factory Voltage (出厂电压)	51V-53V(40-60%)		Mean Operation Voltage (即工作电压)
4	Voltage at end of Discharge (放电终止电压)	40-44V		Discharge Cut-off Voltage (放电截止电压)
5	Charging Voltage (充电电压)	56-58V		
6	Internal Impedance (内阻)	≤50mΩ		Internal resistance measured at AC 1KHz after 50% charge (半电态下用交流法测量内阻) The measure must uses the new batteries that within one week after shipment and cycles less than 5 times (使用出货后不到一个星期及循环次数少于5次的新电池测量)
7	Standard charge (标准充电)	Constant Current 40A Constant Voltage see No.5 0.02CA cut-off (持续电流: 40A 持续电压: 见序号 5 截止电流: 0.02CA)		Charge time : Approx 6 h (充电时间: 大约 6 个小时)
	Limiting current (限流充电)	10A		
8	Standard discharge (标准放电)	Constant current: 40A end voltage see NO.4 (持续电流: 40A 截止电压: 见序号 4)		
9	Maximum Continuous Charge Current (最大充电持续电流)	100A		T ≥ 10°C
10	Maximum Continuous Discharge Current (最大放电持续电流)	200A		T ≥ 10°C
11	Operation Temperature Range (工作温度范围)	Charge (充电) : 0~45°C		60±25%R.H. Bare Cell (单体电池储存湿度范围)
		Discharge (放电) : -20~55°C		
12	Storage Temperature Range (储存温度范围)	Less than 12 months : -10~35°C (小于 12 月: -10~35°C)		60±25%R.H. at the shipment state (出货状态时的湿度范围)
		less than 3 months: -10~45°C (小于 3 个月: -10~45°C)		
		Less than 7 day : -20~65°C (小于 7 天: -20~65°C)		
13	Dimensions (尺寸)	680*485*180 (220)mm		Include Bracket
14	Weight (重量)	Approx : 107kg		

### 3. Battery Management System Specification 电池管理系统规范

#### 3.1 BMS function introduction (BMS 功能介绍)

1) : The BMS is designed for 15/16 series lithium battery. (BMS 为 15/16 串锂离子电池设计)

2) : The BMS have all functions which are : (该 BMS 系统具有以下一些功能)

overcharge detection function (过充电保护功能)

over discharge detection function (过放电保护功能)

over current detection function (过电流保护功能)

short detection function (短路保护功能)

Temperature detection function (温度保护功能)

balance function (均衡功能)

communicate function (通讯功能)

Alarm function (告警功能)

Total capacity function (总容量功能)

Storage history function (存储历史记录功能)

#### 3.2 BMS Protect parameter (电池管理系统保护参数)

Items	Details	Standard
Cell overcharge protection	Overcharge detection voltage	3.65 ± 0.025V
	Overcharge detection delay time	Typical:1.0s
	Overcharge release voltage	3.38 ± 0.02V
Cell over-discharge protection	Over-discharge detection voltage	2.7 ± 0.02V
	Over-discharge detection delay time	Typical:1.0s
	Over-discharge release voltage	2.9 ± 0.02V or charge release
Over-current protection	discharge Over-current protection current1	205A
	discharge Over-current detection delay time 1	1S
	discharge Over-current protection current2	210A
	discharge Over-current detection delay time2	≤100m ± 50ms
	Charge OC protection current	205A
Short protection	Short protection current	Write program (not set)
	Protection condition	Load short
	Detection delay time	Write program (not set)
	Protection release condition	Charging release
Temperature(T) protection	Charge high T protection	55 ± 3 °C
	Charge high T recover	50 ± 5 °C
	Discharge high T protection	65 ± 5 °C
	Discharge high T recover	60 ± 5 °C
	Charge low T protection	-5 ± 5 °C

	Charge low T recover	0±5℃
	Discharge low T protection	-20±5℃
	Discharge low T recover	-15±5℃
Balance	Balance threshold voltage	3.45V
Communication	It has Can and RS485 standard communication interface, it can real-time monitoring the capacity of battery bank, the voltage, current, environment temperature, and charging/discharging current.	
Alarm	It has over-temperature, over charge, under-voltage, over-current, short circuit alarm Function.	
Alarm	It has over-temperature, over charge, under-voltage, over-current, short circuit alarm Function.	

## 4. Appearance and structural dimensions 外观结构尺寸

There shall be no such defect as scratch, bur and other mechanical scratch, and the connector should be no rust dirt. The structure and dimensions see attached drawing of the battery.

电池的表面应无明显的划痕毛刺及其其它机械划伤，外露的金属端子应无锈蚀污垢。

结构尺寸见电池的外形尺寸图：

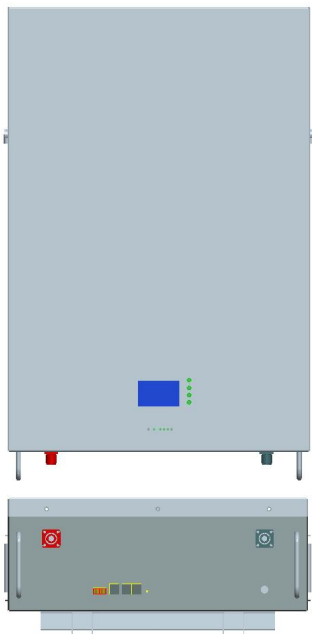

Unit 单位 (mm)					
T (厚度)	680	W(宽度)	485	H (高度)	180
L(外露线长)	/	WIRE (引线)	/	端子型号	8mm 快插头
备注	输出线：线径 35mm <sup>2</sup> ，长度 2m				

## 5. Case Structure of Battery Pack 电池组面板结构定义

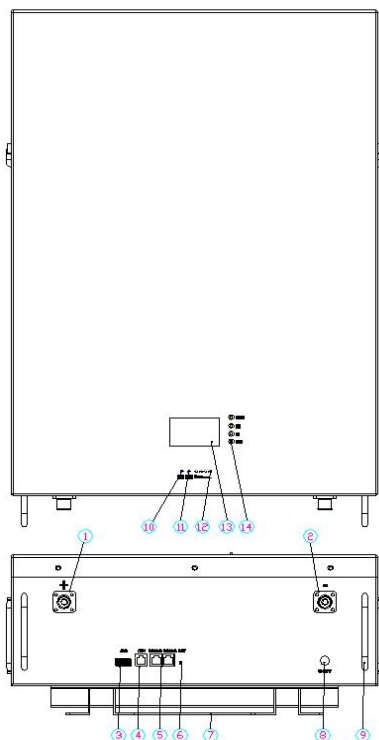

面板标示对应下面说明

No.	Description	Silk-screen	Remark
1	UES0600	P+	Output terminal
2	UES0600	P-	Output terminal
3	Dial switch	ADS	Set the address
4	CANbus Port	CANbus	CANbus and inverter connection port
5	RS485 Port	RS485	RS485 and inverter connection port
6	port Reset button	RST	For reset the batter
5	Do		
6	CANbus Port	CANbus	CANbus and inverter connection port
7	Bracket		
8	Switch	ON/OFF	
9	Handle		
10	LED	RUN	Operation indicator
11	LED	ALM	Alarm indicator
12	LED	CAPACITY	Capacity indicator
13	LCD		
14	LCD Key		



## 6. Connection mode for parallel communication (并机通讯联接)

### 6.1 Address Switch function (Only in Parallel) (地址设置)

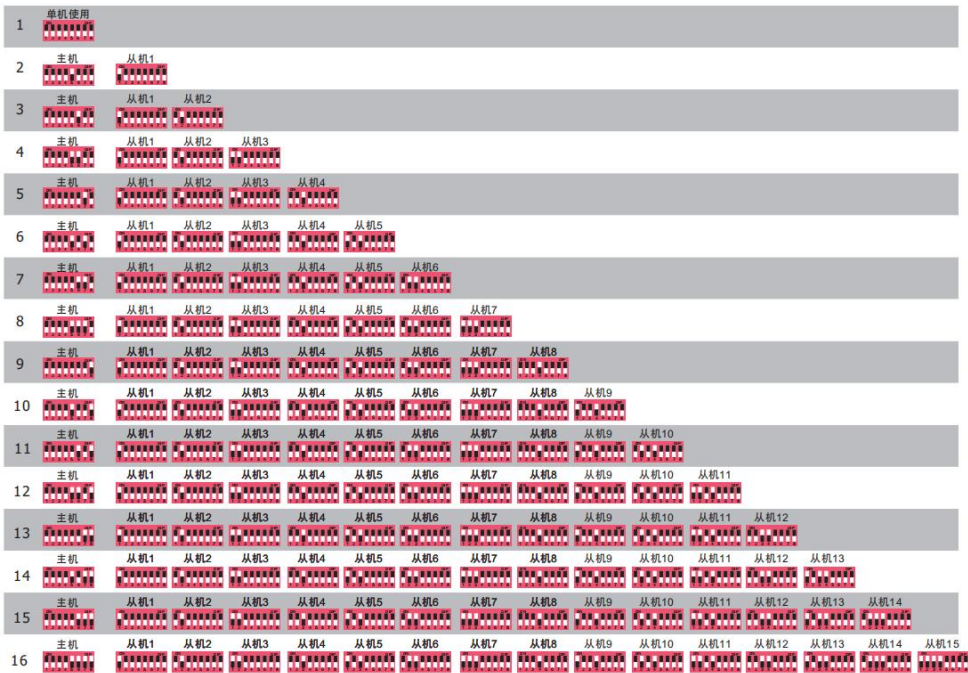

## 7. Packaging of Battery Pack(电池组包装)

电池组包装后尺寸:



4 组电池装木箱后尺寸(the package size of 4pcs ): 1350\*950\*820mm

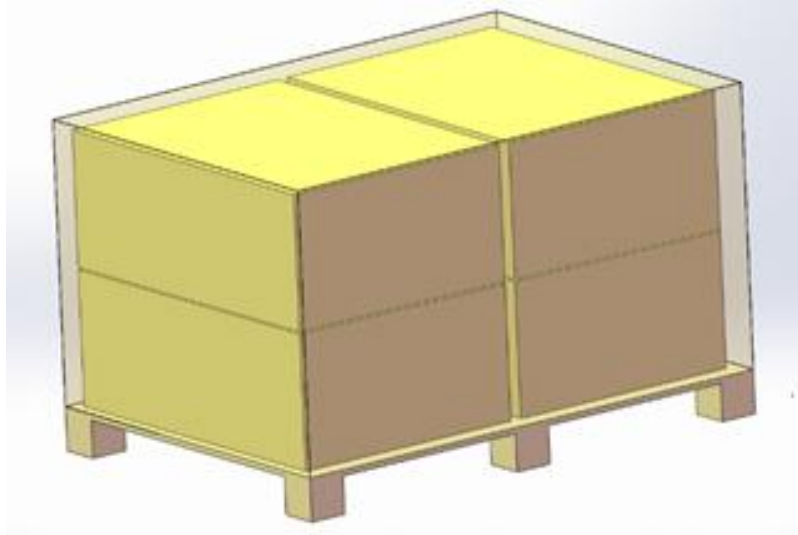

6 组电池装木箱后尺寸(the package size of 6pcs ): 1350\*950\*1150mm

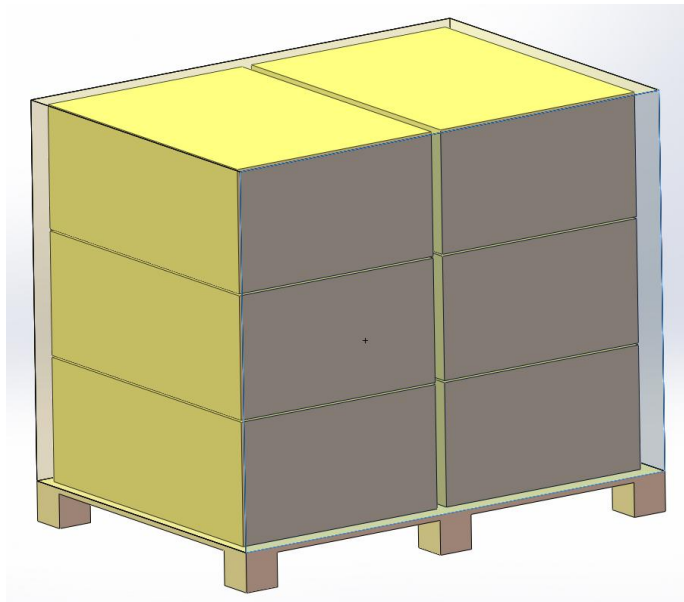

## 8. Battery test equipment 电池测试设备

### 8.1 Dimension Measuring Instrument 尺寸测量仪器

The dimension measurement shall be implemented by instruments with equal or more precision scale of 0.1mm.

测量尺寸的仪器的精度应不小于 0.1mm

### 8.2 Voltmeter 电压表

Standard class specified in the national standard or more sensitive class having inner impedance not less than 10 K $\Omega$ /V.

国家标准或更灵敏等级,内阻不小于 10 K $\Omega$ /V.

### 8.3 Ammeter 电流表

Standard class specified in the national standard or more sensitive class. Total external resistance including ammeter and wire is less than 0.01 $\Omega$ .

国家标准或更灵敏等级,外部总内阻包括电流表和导线应小于 0.01 $\Omega$ .

## 8.4 Impedance Meter 内阻测试仪

Impedance shall be measured by a sinusoidal alternating current method(AC 1kHz LCR meter).  
内阻测试仪测试方法为交流阻抗法(AC 1kHz LCR).

## 9. Standard Test Condition 标准测试条件

Test should be conducted with new batteries within one month after shipment from our factory and the cells shall not be cycled more than five times before the test. Unless otherwise defined, test and measurement shall be done under temperature of  $23\pm 2^{\circ}\text{C}$  and relative humidity of less 75%, air 86Kpa~106Kpa.

测试电池必须是本公司出厂时间不超过一个月的新电池，且电池未进行过五次以上充放电循环。除非其它特殊要求，本产品规格书规定的测试的环境条件为：温度  $23\pm 2^{\circ}\text{C}$ ，相对湿度  $\leq 75\%$ ，气压 86Kpa~106Kpa.

Unless otherwise defined, 30min, rest period after charge, 30min, rest period after discharge.  
如无特殊要求，电池充放电间隔为 30min。

## 10. Storage and Others 贮存及其它事项

### 10.1 Long Time Storage 长期贮存

If stored for a long time(don't used, exceed three months), the cell should be stored in drying and cooling place. The cell's storage voltage should be 51V-53V and the cell is to be stored in a condition that the temperature of  $23\pm 2^{\circ}\text{C}$  and the humidity of 45%- 75%. Long-term use of unused batteries to recharge every 3 months. Ensure that the battery voltage is within the above range.  
长期贮存的电池（未使用，超过 3 个月）须置于干燥、凉爽处。贮存电压为 51V-53V。储存于  $23\pm 2^{\circ}\text{C}$ ，湿度为 45%-75%的洁净环境。长期搁置未使用电池每 3 个月补电一次，确保电池电压在上述范围内。

### 10.2 Others 其它事项

Any matters that this specification does not cover should be conferred between the customer and Giant Power

任何本规格书中未提及的事项，须经双方协商确定

## 11. Amendment of this Specification 产品规格书的修订

This specification is subject to change with prior notice.

本公司有权对本产品规格书进行修订。

## 12. Appendix 附录

**Handling Precautions and Guideline  
For Li-ion Rechargeable Batteries  
锂离子充电电池操作指示及注意事项**

## Preface 前言

This document of 'Handling Precautions and Guideline Li-ion Rechargeable Batteries' shall be applied to the battery cells manufactured by Shenzhen Giant Power Co., Ltd.

本檔“锂离子充电电池操作指示及注意事项”仅适用于深圳市巨博能源有限公司生产电池。

### Note (1) : 声明一

The customer is requested to contact Shenzhen Giant Power Co., Ltd. in advance, if and when the customer needs other applications or operating conditions than those described in this document. Additional experimentation may be required to verify performance and safety under such conditions.

客户若需要将电池用于超出本规格书规定以外的设备，或在本规格书规定以外的使用条件下使用电池，应事先联系深圳市巨博能源有限公司，因为需要进行特定的实验测试以核实电池在该使用条件下的性能及安全性。

### Note (2) : 声明二

Shenzhen Giant Power Co., Ltd. will take no responsibility for any accident when the cell is used under other conditions than those described in this Document.

对于在超出本规格书规定以外的条件下使用电池而造成的任何意外事故，深圳市巨博能源有限公司概不负责。

### Note (3): 声明三

Shenzhen Giant Power Co., Ltd. will inform, in a written form, the customer of improvement(s) regarding proper use and handling of the cell, if it is deemed necessary.

如有必要，深圳市巨博能源有限公司会以书面形式告知客户有关正确操作使用电池的改进措施。

## Danger! 危 险!

- Do not immerse the battery in water or allow it to get wet.
- 勿将电池投入水中或将其弄湿!
- Do not use or store the battery near sources of heat such as a fire or heater.
- 禁止在火源或极热条件下给电池充电! 勿在热源(如火或加热器)附近使用或贮存电池! 如果电池泄漏或发出异味, 应立即将其从接近明火处移开;
- Do not use any chargers other than those recommended by .
- 请使用专用充电器!
- Do not reverse the positive(+) and negative(-) terminals.
- 勿将正负极接反!
- Do not connect the battery directly to wall outlets or car cigarette-lighter sockets.
- 勿将电池直接连接到墙上插座或车载点烟式插座上!
- Do not put the battery into a fire or apply direct heat to it.
- 勿将电池投入火中或给电池加热!
- Do not short-circuit the battery by connecting wires or other metal objects to the positive(+) and negative(-) terminals.
- 禁止用导线或其它金属物体将电池正负极短路, 禁止将电池与项链、发夹或其它金属物体一起运输或贮存!
- Do not pierce the battery casing with a nail or other sharp object, break it open with a hammer, or step on it.
- 禁止用钉子或其它尖锐物体刺穿电池壳体, 禁止锤击或脚踏电池!
- Do not strike, throw or subject the battery to sever physical shock.
- 禁止撞击、投掷或者使电池受到机械震动

- Do not directly solder the battery terminals.
- 禁止直接焊接电池端子！
- Do not attempt to disassemble or modify the battery in any way.
- 禁止以任何方式分解电池！
- Do not place the battery in a microwave oven or pressurized container.
- 禁止将电池置入微波炉或压力容器中！
- Do not use the battery in combination with primary batteries(such as dry-cell batteries) or batteries of different capacity, type or brand.
- 禁止与一次电池（如干电池）或不同容量、型号、品种电池组合使用！
- Do not use the battery if it gives off an odor, generates heat, becomes discolored or deformed, or appears abnormal in any way. If the battery is in use or being recharged, remove it from the device or charger immediately and discontinue use.
- 如果电池发出异味、发热、变形、变色或出现其它任何异常现象时不得使用；如果电池正在使用或充电，应立即从用电器中或充电器上取出并停止使用！

### **Caution!**

### **注 意！**

Do not use or store the battery where is exposed to extremely hot, such as under window of a car in direct sunlight in a hot day. Otherwise, the battery may be overheated. This can also reduce battery performance and/or shorten service life.

不要使用处于极热环境中的电池，如阳光直射或热天的车内。否则，电池会过热，可能着火（点燃），这样就会影响电池的性能、缩短电池的使用寿命。

If the battery leaks and electrolyte gets in your eyes, do not rub them. Instead, rinse them with clean running water and immediately seek medical attention. If left as is, electrolyte can cause eye injury.

如果电池漏液后电解液进入眼睛，不要擦，应用水冲洗，立即寻求医疗救助。如不及时处理，眼睛将会受到伤害。